

Reinforced Type 1 Cut-Off Wheel (Type 41)



Diamond Wheel

Abrasive Cutting Tools



65VBW;5000;12

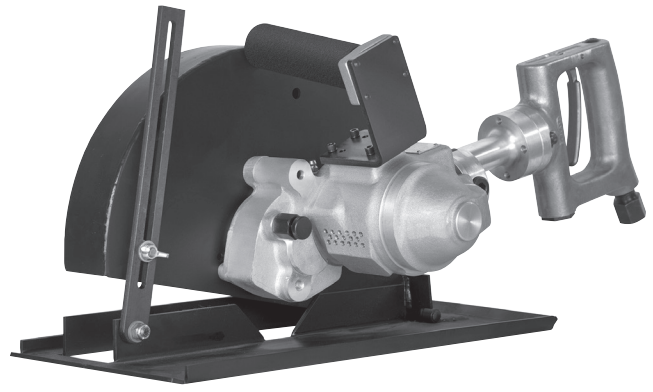

662VBW;3300;14

Guard Size	Spindle Type	Operating Speed	MODEL NUMBER	Guard Size	Spindle Type	Operating Speed	MODEL NUMBER
9 Inch	5/8-11	6000 RPM	65VBW;6000;941				
12 Inch	1" Spline	5000 RPM	65VBW;5000;1241	12 Inch	1" Spline	3300 RPM	662VBW;3300;1241
14 Inch		4000 RPM	65VBW;4000;1441	14 Inch			662VBW;3300;1441

Dimensions shown are for 12" guard. Other guards vary slightly.

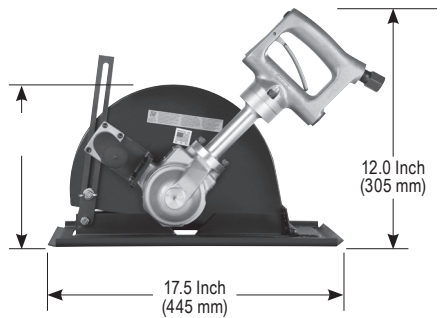

Dimensions shown are for 14" guard. Other guards vary slightly.

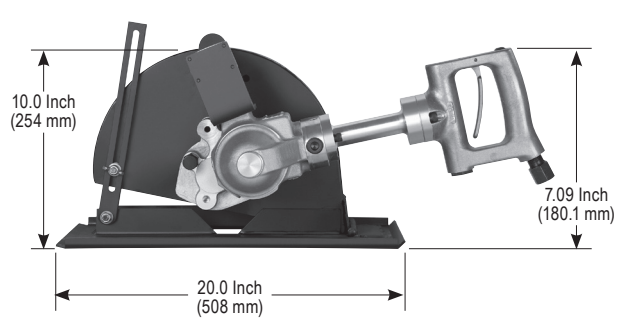

HP 4.0 H.P. (3000 W)

cfm 25 cfm (11.8 L/s) Free
75 cfm (35.4 L/s) Max

Lbs 65VBW: 23.9 Lbs. (10.8 Kg)
662VBW: 28.3 Lbs. (12.8 Kg)

SUPPLY 1/2" NPT Inlet
1/2" (13mm) Hose Size

STANDARD EQUIPMENT

- Tool
- Operating Instructions and Service Manual
- Wrenches (sizes based on options)

Model Number	Depth of Cut		
	Guard Size		
	9 Inch (230mm)	12 Inch (300mm)	14 inch (360mm)
65VBW	2.5 Inch (64mm)	3.3 Inch (84mm)	4.3 Inch (109mm)
662VBW	N/A		



Wet Cutting Attachment